

TEKNISET TIEDOT

TECHNICAL DATA

TEKNISKA DATA

TECHNISCHE DATEN

DONNÉES TECHNIQUES

DATOS TÉCNICOS

ESPECIFICAÇÕES TÉCNICAS

DATI TECNICI

ТЕХНИЧЕСКИЕ ДАННЫЕ

技術面データー

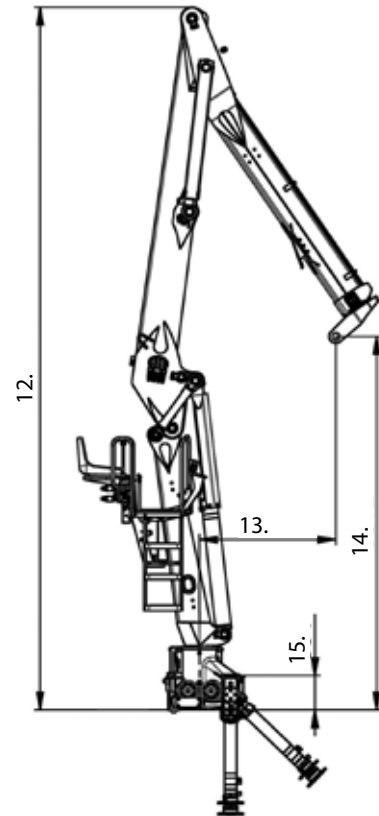
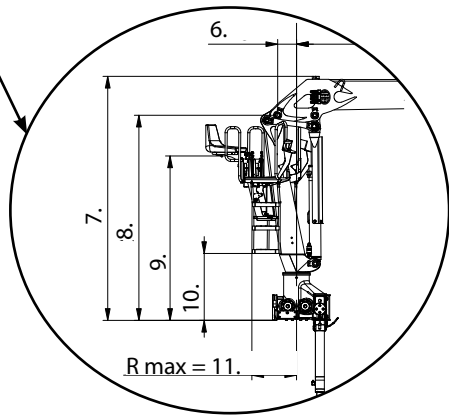
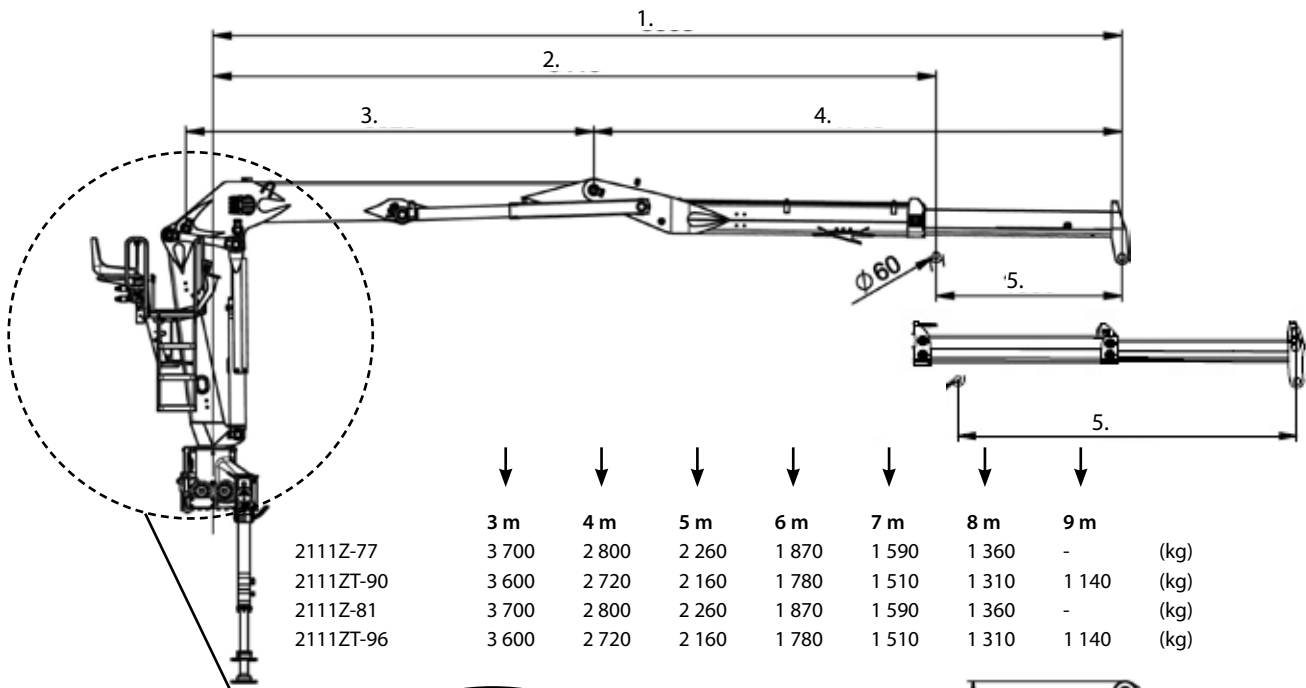

	2111Z-77	2111ZT-90	2111Z-81	2111ZT-96
1.	7 720	8 950	8 090	9 575
2.	6 070	6 050	6 440	6 475
3.	3 320	3 320	3 620	3 620
4.	4 620	5 850	4 710	6 195
5.	1 650	2 900	1 650	3 100
6.	220	220	240	240
7.	2 839	2 839	2 946	2 946
8.	2 400	2 400	2 500	2 500
9.	1 945	1 945	2 040	2 040
10.	780	780	880	880
11.	615	615	625	625
12.	5 835	5 835	6 232	6 232
13.	1 119	1 119	1 207	1 224
14.	2 979	2 987	3 312	3 263
15.	304	304	304	304

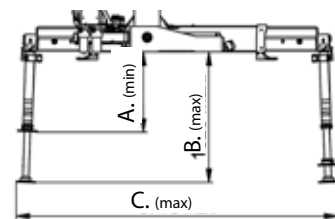

	ALT. 1.	ALT. 2.
A.	838	941
B.	1 362	1 362
C.	3 759	3 772

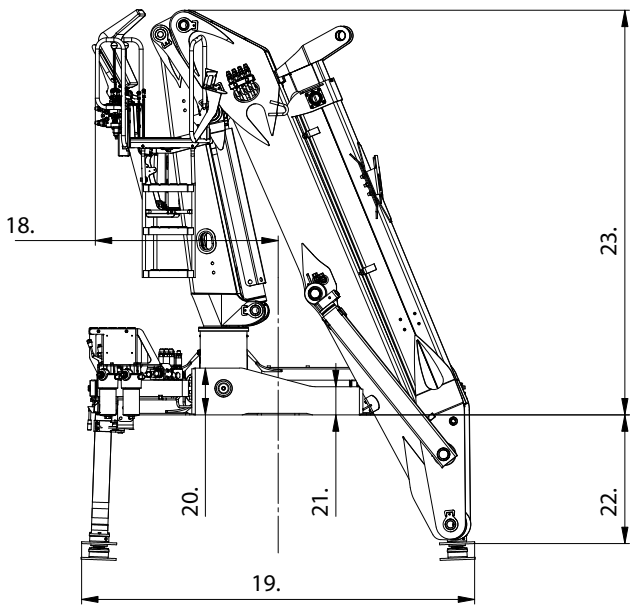

	2111Z-77	2111ZT-90	2111Z-81	2111ZT-96
18.	1 160	1 160	1 180	1 180
19.	2 500	2 500	2 500	2 500
20.	300	300	300	300
21.	160	160	160	160
22.	625	625	826	826
23.	2 495	2 495	2 595	2 595
24.	1 144	1 144	1 144	1 144
25.	850	850	850	850
26.	1 095 - 1 275	1 095 - 1 275	1 120 - 1 300	1 120 - 1 300
27.	1 045 - 1 225	1 045 - 1 225	1 070 - 1 250	1 070 - 1 250

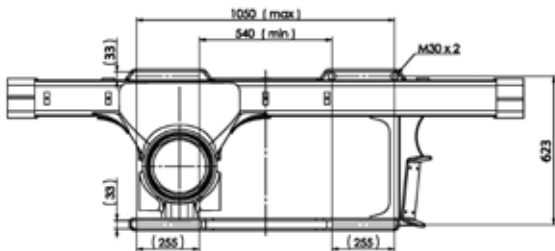
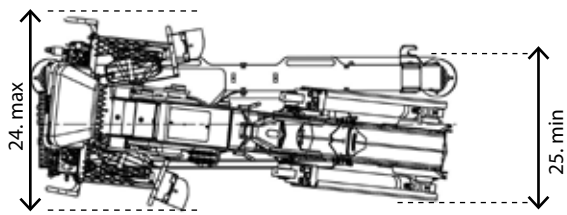

26. TOP-SEAT STD

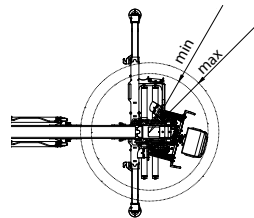

27. TOP-SEAT E

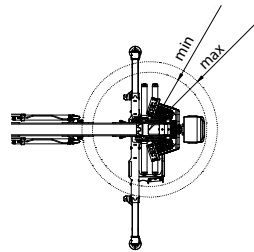

SLEWING OPTIONS

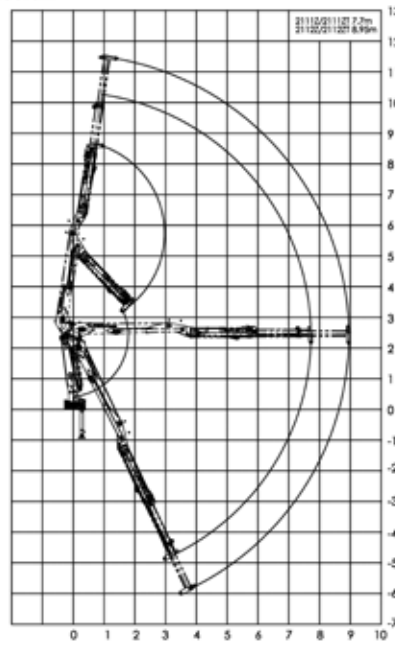
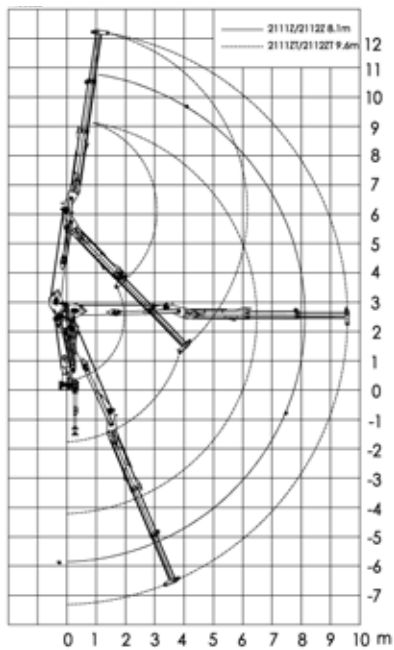
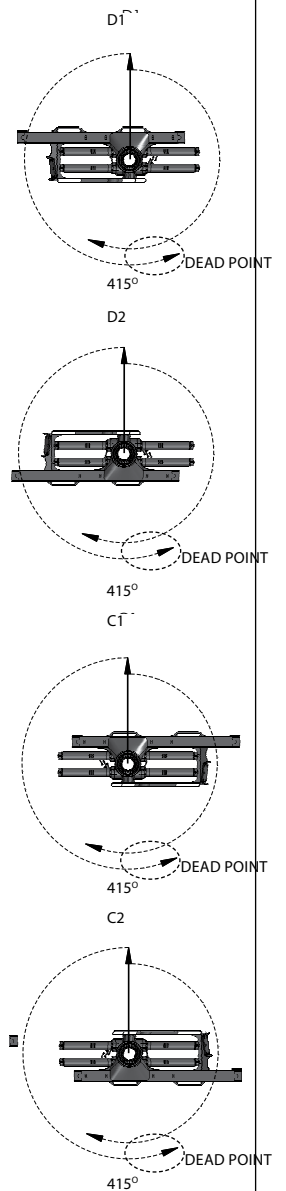

	2111Z-77	2111ZT-90	2111Z-81	2111ZT-96	
Nostomomentti (netto) • Lifting capacity (net) • Lyftmoment (netto) • Hubmoment (netto) • Couple de levage (net) • Capacidad de elevación (neto) • Binário de elevação • Prestazione (netta) • Момент подъема (нетто) • リフティングトルク (正味値)	(kNm)	112	107	110	105
Max. ulottuvuus • Max. outreach • Räckvidd • Reichweite • Portée • Alcance • Alcance máximo • Braccio max • Максимальный вылет • 最大伸び寸法	(mm)	7 720	8 950	8 090	9 575
Jatkeen pituus • Hydraulic boom extension • Utskjut • Ausschub • Rallonge • Extensión del brazo • Extensões • Sfilo idraulico • Удлинитель • 延長の長さ	(mm)	1 650	2 x 1 450	1 650	2 x 1 550
Kääntömomentti • Slewing torque • Vridmoment • Schwenkmoment • Couple de rotation • Torsión de rotación • Binário de rotação • Coppia di rotazione • Момент поворота • 回轉トルク	(kNm)	23	23	23	23
Kääntökulma • Slewing angle • Vridvinkel • Schwenkwinkel • Angle de rotation • Ángulo de rotación • Ángulo de rotação • Rotazione • Угол поворота • 回轉角度	(°)	415	415	415	415
Suosittelava hydr. tuotto • Recommended oil flow • Rek. oljeflöde • Empfohlene Pumpenleistung • Recommandation pour la pompe • Recomendación para la bomba • Requisitos hidráulicos • Mandata olio raccomandata • Рекомендуемый гидронасос • 油流量の推奨					
▶ 1-piiri • single circuit • 1-krets • 1-Kreis • simple circuit • Un circuito • Uma bomba • Un circuito • 1 контур • 1-回路	(l/min)	-	-	-	-
▶ 2-piiri • double circuit • 2-krets • 2-Kreis • double circuit • Doble circuito • Dois bombas • Doppio circuito • 2 контура • 2-回路	(l/min)	2 x 70 - 90	2 x 70 - 90	2 x 70 - 90	2 x 70 - 90
▶ LS • LS (荷重出)	(l/min)	180 - 200	180 - 200	180 - 200	180 - 200
Työpaine • Operating pressure • Arbetstryck • Arbeitsdruck • Pression de fonctionnement • Presión de trabajo • Presión de operación • Pressione di lavoro • рабочее давление • 作動力	(MPa)	26	26	26	26
Paino sis. nosturin avohallintalaitteella ilman kahmariä, kääntäjää ja öljyä. Weight including the crane with top-seat, without the grapple, rotator and oil. Vikt inkl. kran med sittnock, utan gripare, rotator och ölja. Gewicht mit Hochsitz und mech. Steuerung, ohne Greifer, ohne Gelenk - Rotator und ohne Öl. Poids de la grue avec siege, sans le grappin, rotateur et l'huile. Peso incluyendo equipamiento de control y estabilizadores. Menos la garra, rotor y aceite hidráulico. Peso sem óleo, grappa, estabilizadores, rotador. Peso con comandi alti, senza pinza, rotatore e olio. Вес с приборами управления, без грейфера, ротора и гидромасла. グラッフル無しでローダーのコントロール置を含む重量、回置と油オイル。	(kg)	2370	2470	2380	2530

Datasheet_KESLA_2111Z_ZT_10_2018

Valmistajan antamat arvot ovat ohjeellisia. Kesla pidättää oikeuden muutoksiin.

The values provided by the manufacturer are indicative. Kesla reserves the right to make changes.

De lämnade värdena av tillverkaren är riktgivande. Kesla förbehåller sig rätten till ändringar.

Die Angaben des Herstellers sind Richtwerte. Kesla behält sich das Recht auf Änderungen vor.

Les valeurs communiquées par le fabricant sont seulement indicatives. Kesla se réserve le droit à toutes modifications.

Los datos ofrecidos por el fabricante son orientativos. Kesla se reserva el derecho de modificarlos.

Os valores pelo fabricante são indicativas. Kesla reserva-se o direito de fazer alterações.

I dati del costruttore sono indicativi. Kesla si riserva il diritto di modificarli.

Приводимые изготовителем показатели являются индикативными. Изготовитель оставляет за собой право на изменения.

メーカーによる値はあくまでも基本表示です。KESLAは更なる利を保留します。

Classification according: EN12999:2011 HC1/HD4/B4

KESLA



Kesla Oyj
Kuurnankatu 24
FI-80100 JOENSUU, FINLAND
Tel. +358 207 862 841
Fax +358 13 610 0521
www.kesla.com

